

Honeywell

EN Portable Evaporative Air Cooler
User Manual

Read and save these instructions before use

FR Refroidisseur d'air par évaporation portatif
Mode d'emploi

Lire ces instructions avant l'utilisation et les conserver

ES Enfriador de Aire Evaporativo Portátil
Manual de Instrucciones

Lea y guarde estas instrucciones antes de usar la unidad

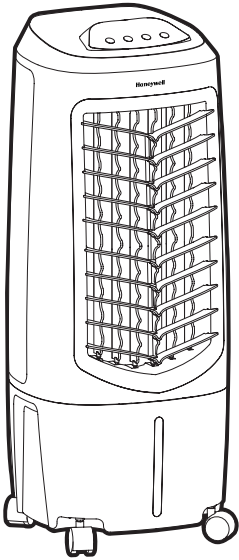

Model / Modèle / Modelo:

TC10PE Series / Série / Serie

Customer Support:

Assistance Au Client:

Servicio de atención a clientes:

USA/ EE.UU: 1-800-474-2147

CANADA/ CANADÁ^ : 1-888-209-0999

^ Canada Customer Support service available for models sold in Canada only.

^ Le Service Client Canadien est disponible uniquement pour les modèles vendus sur le territoire Canadien.

^ Servicio de Atención A Clientes en Canadá disponible solo para modelos vendidos en Canadá.

www.jmatek.com

Email: usinfo@jmatek.com

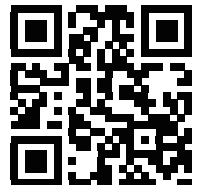

PARTS DESCRIPTION

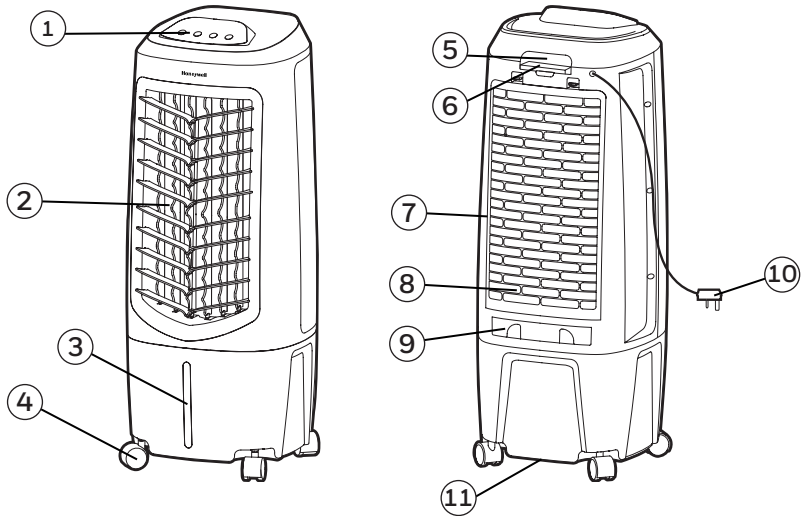

1) Control Panel

2) Louvers

3) Water Level Indicator

4) Casters

5) Handle

6) Remote Control

7) Rear Grill & Mesh Filter

8) Honeycomb Cooling Media

9) Water Fill Door

10) Power Cord & Plug

11) Drain Plug

WARNING -- READ AND SAVE THE AIR COOLER SAFETY & MAINTENANCE GUIDE AND USER MANUAL BEFORE USING THIS PRODUCT. FAILURE TO FOLLOW THESE INSTRUCTIONS MAY DAMAGE AND/ OR IMPAIR ITS OPERATION AND VOID THE WARRANTY. IN CASE THERE IS ANY INCONSISTENCY OR CONFLICT BETWEEN THE ENGLISH VERSION AND ANY OTHER LANGUAGE VERSION OF THE CONTENT OF THIS MATERIAL, THE ENGLISH VERSION SHALL PREVAIL.

CONTROL PANEL

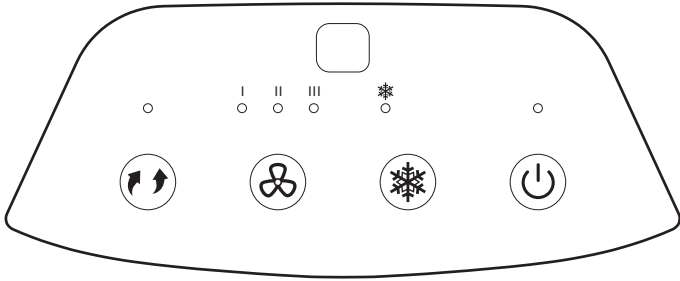

Icons on Display Screen



Power



Swing



Cool



Speed

I = Low

II = Medium

III = High

FUNCTION BUTTONS

POWER

Press the button  to turn the unit on. The cooler will start automatically at medium speed. After a few seconds the speed will switch to low. To turn the unit off, press the button again.

SPEED



Press the SPEED  button repeatedly to change the speed between I - II - III.

SWING

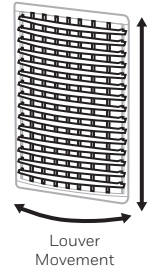
Press the SWING button until  is illuminated on the display. The louvers will begin to move left to right automatically. You can manually adjust the louvers to change vertical air flow.





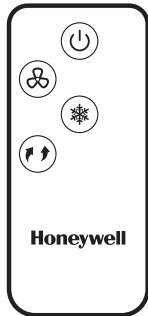

COOL

You must add water before operating the unit in Cool mode. Press  the button until  is illuminated on the display screen. The water pump will operate and you will feel the cooler air after the Honeycomb Cooling Media is completely wet.

REMOTE CONTROL



-  POWER : ON / OFF
-  SPEED : Low / Medium / High
-  COOL : Evaporative Cooling ON / OFF
-  SWING : Controls the motion of the louvers

NOTE:

- The remote control requires a CR2025 (1 x 3V) coin type or equivalent battery for replacement. Open the battery compartment at the back of the remote control and insert the battery inside. Care must be taken to insert the batteries according to the correct polarity (+ / -) markings shown inside the battery compartment.
- Always point the remote control signal transmitter towards the unit when operating. Make sure that the signal path is not obstructed.
- Remove the batteries if the unit is not going to be used for an extended period of time.
- Do not drop the remote control.
- Do not mix different types of batteries such as alkaline, carbon-zinc, or rechargeable batteries.
- Do not mix old and new batteries.
- Do not recharge the battery.
- Exhausted batteries are to be removed from the product and safely disposed of as per local regulations.
- Do not dispose of batteries in fire. Batteries may explode or leak.
- This product contains a lithium button/coin cell battery. If a new or used lithium button/ coin cell battery is swallowed or enters the body, it can cause severe internal burns and can lead to death in as little as 2 hours. Always completely secure the battery compartment. If the battery compartment does not close securely, stop using the product, remove the batteries, and keep it away from children. If you think batteries might have been swallowed or placed inside any part of the body, seek immediate medical attention.
- The batteries shall be disposed of properly, including keeping them away from children.
- Even used batteries may cause injury.

 **WARNING:** Chemical Burn Hazard. Keep batteries away from children.

COOLER LOCATION

Make sure to position the air cooler correctly before you set up and start using the product. Please refer to the COOLER LOCATION section of the separate Safety & Maintenance Guide.

FILLING WITH WATER

CAUTION: Unplug the unit from the electrical socket before emptying or refilling the water tank.

Open the Water Fill Door located on the back of the unit.

The Water Level Indicator is located at the front of the unit. Refill the water tank when water level is low. Do not fill water above the "Max." water level mark to avoid water droplets collecting on the louvers. Check the water level in the tank before running the COOL function. Make sure that the water in the tank is above the minimum water level mark. Running the unit in COOL mode with inadequate water may cause pump failure.

Note: The water capacity refers to the total volume of water that can be contained within the air cooler water tank and water distribution system. The water capacity in the tank at the "Max." indicator level may be lower than the actual water capacity of the air cooler.

WARNING: Do not fill water tank with dirty water or salt water. This can damage the unit and Honeycomb media.

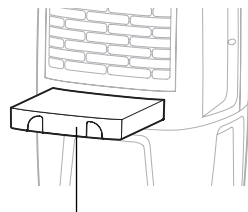

Water Fill Door

LOW WATER ALARM*

The unit is equipped with a low water sensor. In Cooling Mode, when water in the tank is below the minimum level, you will hear a beeping sound and the GREEN LED will flash continuously. The unit will automatically pause evaporative cooling.

Refill the water tank to deactivate the alarm in cooling mode. First switch OFF the unit and unplug from the power outlet. Fill the water tank with water above the minimum water level mark. Plug in and switch ON again.

To deactivate the alarm and continue using the unit as a fan (without evaporative cooling), switch the unit OFF and then ON again. The Low Water Alarm will not activate in Fan only mode. The Low Water Alarm will sound again if the COOL function is activated while the water tank is still empty.

* Applicable for models with Low Water Alarm feature only.

CLEANING & DRAINING THE WATER TANK

Below are instructions on how to clean and maintain your air cooler. If the cooler will not be used for a long period of time, please refer to the STORAGE & MAINTENANCE GUIDELINES located in the separate Safety & Maintenance Guide.

WARNING:

Before cleaning the unit, power OFF the unit and disconnect from the electrical socket.

- Move the unit to a location where the water can be drained. Remove the cap from the drain plug located at the bottom of the unit. Allow the tank to empty.
- Refill the water tank with clean water, up to the maximum level and drain it completely.
- Use a damp cloth to remove the dirt and dust from the surface of the unit. Never use corrosive elements or chemicals to clean this product.
- When the product is not in use, store the unit in a dry place out of direct sunlight.

CLEANING THE MESH FILTER AND HONEYCOMB COOLING MEDIA

WARNING:

Before cleaning the unit, switch the unit OFF and disconnect the power adapter from the unit and electrical socket.

- The appliance is supplied with a Mesh Filter and Honeycomb Cooling Media.
- The Mesh Filter and Honeycomb Cooling Media are located inside the Rear Grill. See Figure 1 for instructions on how to remove them from the unit for cleaning and maintenance.
- Do not run the unit in COOL mode with stale water in the tank. You must empty the water tank and refill with fresh water, especially if the tank has not been cleaned in a long time.
- The cleaning frequency for the Honeycomb media depends on local air and water conditions. In areas where the mineral content of water is high, mineral deposits may build up on the Honeycomb Cooling Media and restrict air flow. Draining the water tank and refilling with fresh water at least once a week will help reduce mineral deposits. If mineral deposits remain on the Honeycomb Cooling Media, the media should be removed and washed under fresh water. The media should be cleaned every two months or sooner, depending on your needs.
- For best results allow the Honeycomb Cooling Media to dry after each use by turning off the cool function 15 minutes before turning the unit off.

Removing the Mesh Filter and Honeycomb Cooling Media:

1. Carefully pull out the rear grill / mesh filter from the cooler.
2. Rinse the rear grill / mesh filter with clean water and let it dry before re-installing to the unit.
3. Carefully pull out the Honeycomb Media from the Honeycomb Frame.
4. Replace or clean media with water and a damp cloth as needed.

WARNING: DO NOT operate the Air Cooler when the Rear Grill is removed from the Air Cooler, or if there is a loose-fitting Rear Grill. Doing so can cause serious injury or dangerous electrical shock.

Figure 1:

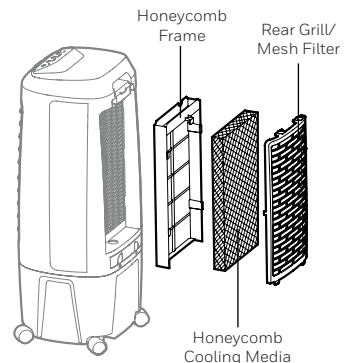

DESCRIPTION DES PIÈCES

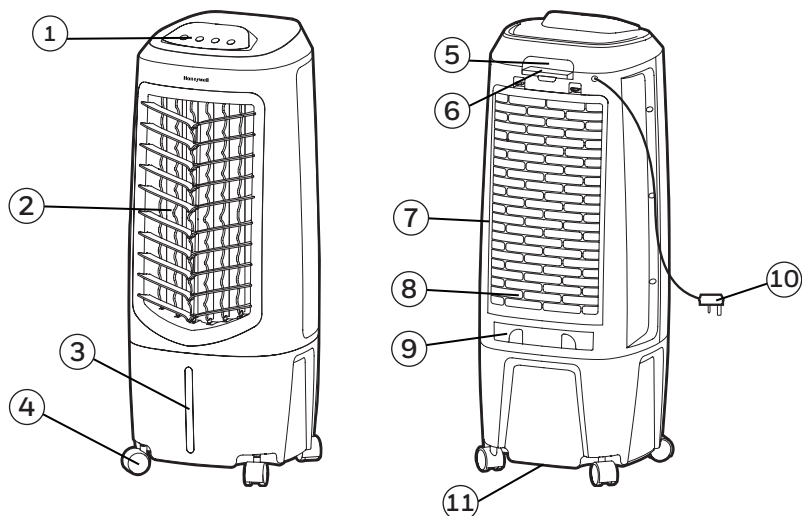

- | | |
|-------------------------------|---|
| 1) Panneau de contrôle | 7) Grille arrière & filter |
| 2) Grilles d'aération | 8) Système de refroidissement en nid d'abeilles |
| 3) Indicateur de niveau d'eau | 9) Porte de remplissage d'eau |
| 4) Roulettes | 10) Cordon électrique & prise |
| 5) Poignée | 11) Bouchon de vidange |
| 6) Télécommande | |

AVERTISSEMENT -- LIRE ET SAUVEGARDER LE GUIDE DE SECURITE ET D'ENTRETIEN ET LE MANUEL D'UTILISATION DU REFROIDISSEUR D'AIR AVANT D'UTILISER LE PRODUIT. NE PAS SUIVRE CES INSTRUCTIONS POURRAIT ENDOMMAGER ET/OU PORTER ATTEINTE A SON FONCTIONNEMENT ET ANNULER LA GARANTIE. EN CAS D'INCOHERENCE OU DE CONFLIT ENTRE LA VERSION ANGLAISE ET TOUT AUTRE VERSION LINGUISTIQUE DU CONTENU DE CE MATERIEL, LA VERSION ANGLAISE PRÉVAUDRA.